

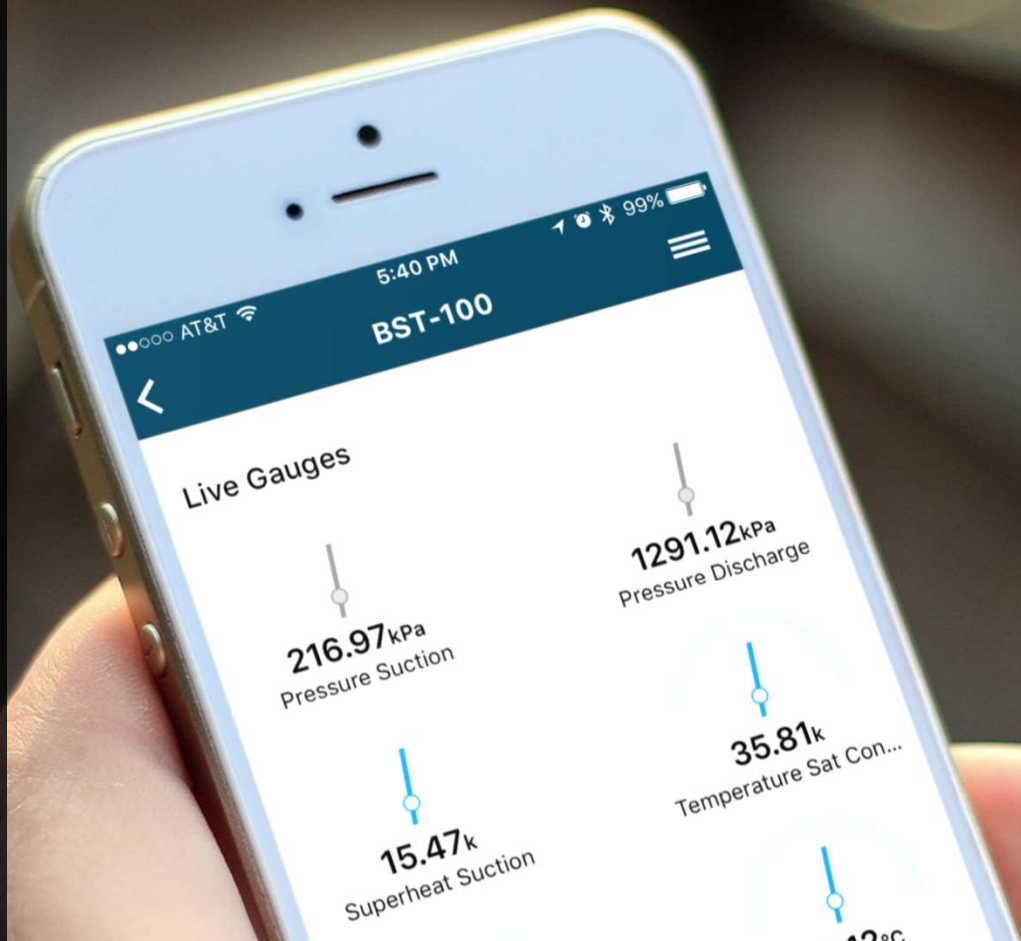

MAKE YOUR HVAC SMART



OptumSoft



BE IN THE KNOW

With SMART HVAC, you'll have the power to know. Thanks to modern advancements in sensor technology, mobile- and cloud computing, you now have full visibility to any HVAC system in the palm of hand. Anytime. Anywhere.

With SMART HVAC, there is no more guessing. No more surprises. No more wrong or wasted repairs.

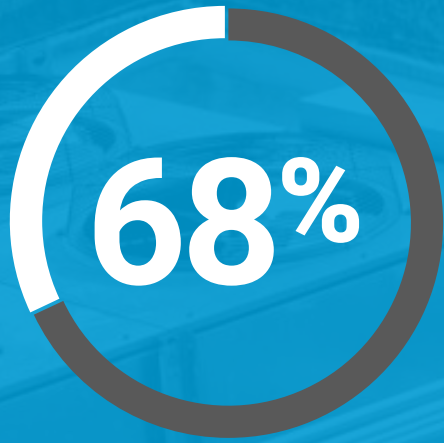

Cut HVAC
maintenance cost
by up to 68%



Add 24 by 7 cloud-based
monitoring to all your HVAC
systems and gain the peace of
mind you have been seeking.



UNIVERSAL HVAC MONITORING

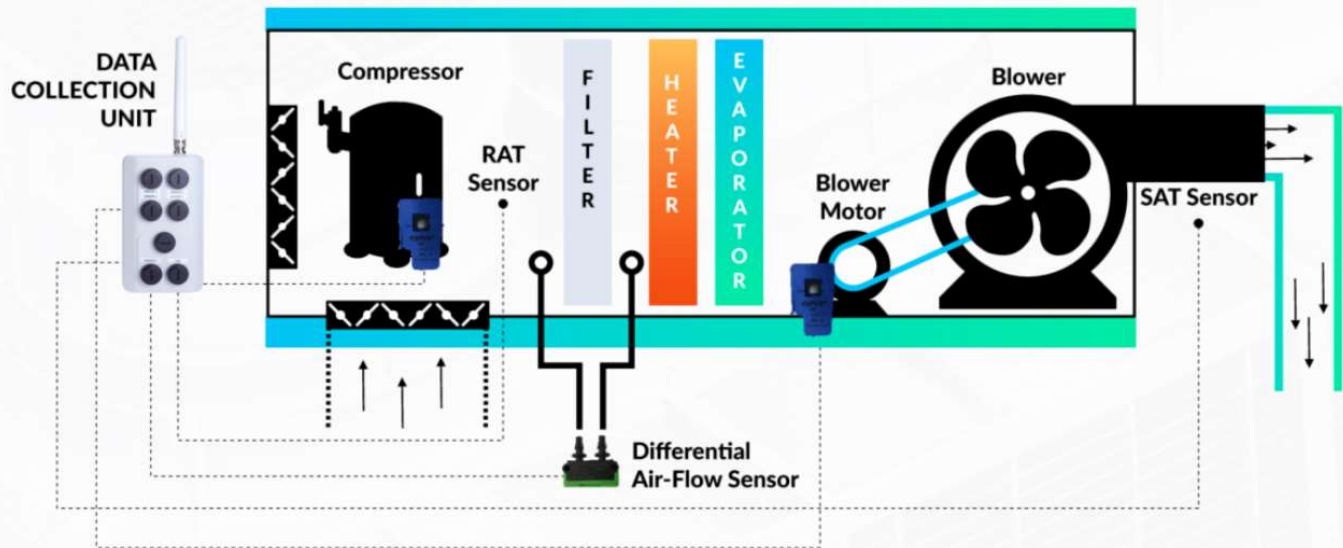

ANY SYSTEM CAN BECOME SMART

In the past, only high-end refrigeration systems had any form of automated monitoring. Out of reach for most operators.

Now, thanks to advances in technology, every HVAC system, new or existing, can now be made smart.

9 VITAL INDICATORS

No more guesswork. Now you may know exactly what's happening. Follow temperature, refrigerant pressures, cycle times, cycle frequency and power consumption down to fans and compressors. View real-time data as well as historical trends. Gain the power, insight and peace of mind that SMART HVAC delivers.

COMPREHENSIVE DATA GATHERING

CLOUD-BASED
DATA COLLECTION UNIT



PRESSURE



TEMP &
HUMIDITY



CURRENT



LINE
TEMP



DOOR



PURPOSE-BUILT SENSORS

CLOUD-BASED MULTI-SITE MONITORING

SMART HVAC across multiple sites have never been easier. Using Cloud Computing, each site wirelessly logs data history and trend analysis. You now can access your HVAC data from anywhere. Whether you are on the road or in a remote office. Use smart phone, tablet or laptop and all the data is there. From every system. From every location. 24/7. Now, that's SMART!

CLOUD-BASED MULTI-SITE PLATFORM



THE SMART-HVAC DIFFERENCE

The Experience	Without SMART HVAC	With SMART HVAC
 Fixing broken parts	After the fact. Run till it breaks.	Predictive. Parts are replaced before they break.
 Impact to Business	Massive. Loss of comfort and productivity.	Minimal. Comfort is ensured via 24/7 monitoring.
 Detecting Outdated Equipment	By inspection only. Time consuming using special tools.	Automatic. Alerting 24/7 from continuous monitoring.
 Multi-Site Visibility	None. No comparison across sites. No reporting.	Full. Cloud-based multi-site analysis and reporting.
 Energy Cost	High. Long cycle times due to failing equipment.	Low. Equipment is running optimally.



www.smartestHVAC.com

OptumSoft, Inc.
200 Middlefield Road,
Suite 112
Menlo Park, CA 94025
United States

GET STARTED
TODAY



 OptumSoft